

[MILLIMETERS]
INCHES

NOTE:
1. AMERICAN NATIONAL STANDARD TAPER PIPE THREADS (NPT) PER ANSI B2.1-1968.
2. VALVES AVAILABLE WITH B.S.P.T. END CONNECTIONS.

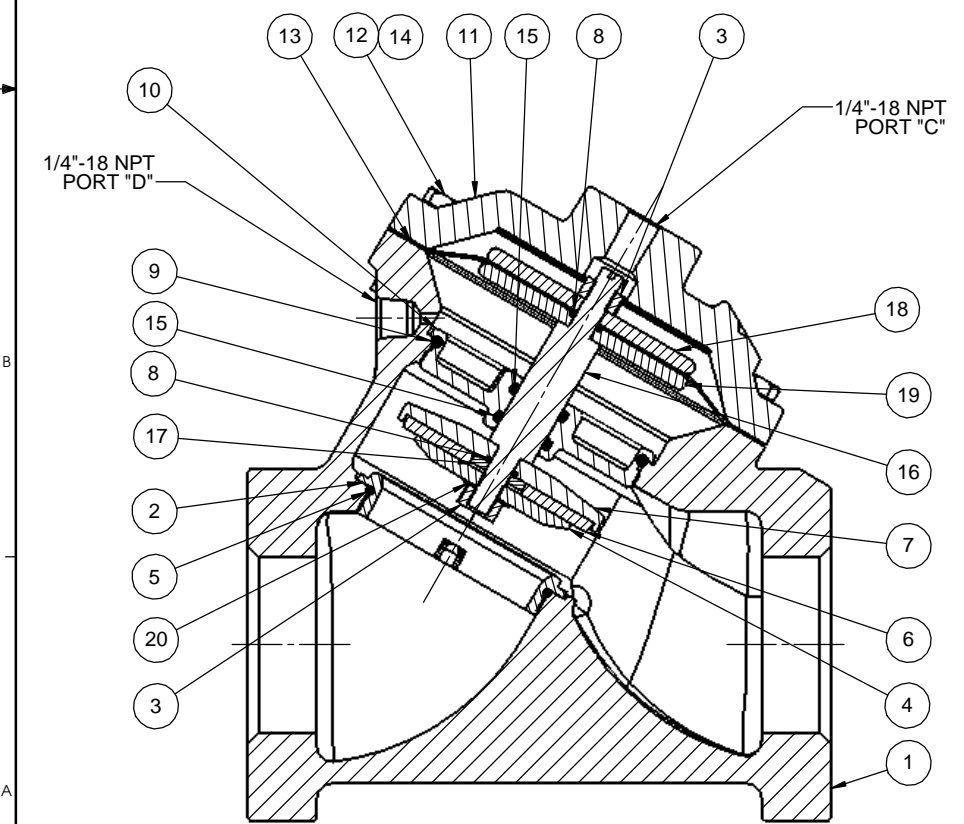

1072489 (VAVG-0000-90000) (2\"NPT)
1072495 (VAVH-0000-90000) (2-1/2\"NPT)
NORMALLY OPEN (STANDARD)

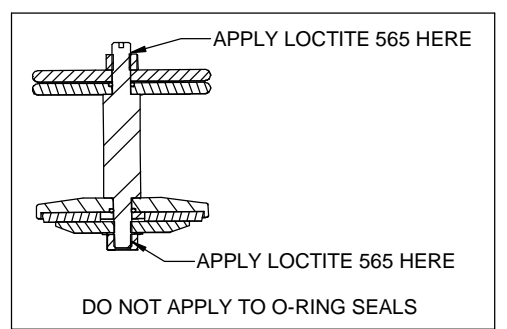

| REVISIONS | | | | | |
|-----------|--------|------|--------------------------------------|----------|-------|
| ZONE | ECN | REV. | DESCRIPTION | DATE | APP'D |
| | 102071 | K | REDRAWN IN SOLID WORKS 1-WAS 1074377 | 06-07-13 | NBE |
| | 102740 | L | 1-WAS: 1074377, NOW: 43244 | 28APR14 | TJM |

| ITEM NO. | DESCRIPTION | PART NUMBER | QTY. | |
|----------|----------------------------------|-------------|---------|---|
| 1 | BODY, 426 (CAST IRON) | 2\" NPT | 1074343 | 1 |
| | | 2 1/2\" NPT | 1081559 | |
| 2 | SEAT, 426, BRASS* | 1074409 | 1 | |
| 3 | NUT, HEX, 5/16\"-24 ,SS | 1263853 | 2 | |
| 4 | DISC PLATE, BRASS | 1074396 | 1 | |
| 5 | O-RING, -144 | FKM | 1071809 | 1 |
| | | HYCAR | 1074392 | |
| 6 | DISC, 426 | FKM | 1074393 | 1 |
| | | | | |
| 7 | HOLDER, DISC, AV6, BRASS | 1074383 | 1 | |
| 8 | O-RING, -011 | FKM | 1071786 | 2 |
| 9 | O-RING, -233 | FKM | 1071826 | 1 |
| 10 | GUIDE, 426 SHAFT* | 43244 | 1 | |
| 11 | CAP, 426, NPT, (CAST IRON) | 1081560 | 1 | |
| 12 | SCREW, HEX HD CAP, 5/16-18X1-3/8 | 1072401 | 6 | |
| 13 | DIAPHRAGM, 426 | BUNA | 1074374 | 1 |
| | | FKM | 1074376 | |
| 14 | HEX NUT, 5/16\"-18, PLATED | 1071657 | 6 | |
| 15 | O-RING, -114 | ALFAS | 1071662 | 2 |
| 16 | SHAFT, 426, NO | 1074401 | 1 | |
| 17 | SPACER, BRASS | 1074382 | 1 | |
| 18 | PLATE, DIAPHRAGM, UPPER, SS | 1074371 | 1 | |
| 19 | PLATE, DIAPHRAGM, LOWER, SS | 1074372 | 1 | |
| 20 | LOCKWASHER** | 1073594 | 1 | |

*REQUIRES ASSEMBLY TOOL
**FOR USE WITH HYCAR DISC ONLY

| ASSEMBLY TOOLS | |
|---|---------------------|
| DESCRIPTION | PART NO. |
| FOR INSTALLATION & REMOVAL OF SEAT (ITEM #2) (TOOL NOT SHOWN) | 1074411 (426-MT) |
| FOR INSTALLATION & REMOVAL OF SHAFT GUIDE (ITEM #10) (TOOL NOT SHOWN) | 1-3/16\" HEX SOCKET |

| REPAIR PARTS KITS | | |
|--|--|--------------------|
| DESCRIPTION | PART NO. | |
| DIAPHRAGM & SEAL KIT CONSISTS OF ITEM NO'S 3(2), 5, 6, 8(2), 9, 13, & 15(2) | 1070109 (AV6-RA) | 1070510 (AV6-RAHT) |
| | INCLUDES DISC P/N 1074392 (HYCAR) AND DIAPHRAGM P/N 1074374 (BUNA N) | |
| INT. PARTS KIT (NORM. OPEN) CONSIST OF STANDARD ITEM NO'S 4, 7, 10, 16, 17, 18, 19 | 10705011 (AV6-RF) | |
| SEAT (ITEM NO. 2) | 1074407 | |

SEE REVERSE SIDE FOR CONFIGURATION OPTIONS

| | | | | |
|---|------------------------|------|--|--------------|
| © 2016 AQ Matic Valve and Controls Company, Inc. All rights reserved. | THIRD ANGLE PROJECTION | | 16605 West Victor Rd New Berlin, WI 53151 262-326-0100 www.aq-matic.com | |
| | APPROVALS | | DATE | TITLE |
| DO NOT SCALE DRAWING. DIMS. ARE IN INCHES [mm] INTERPRET DIMS AND TOLERANCES PER ASME Y14.5M-2009 UNLESS OTHERWISE SPECIFIED. ALL FINISHED MACHINED SURFACES 125/ OR BETTER. TOLERANCES: ANGLES: ± 1° 1 PLACE .XX ± 0.015 [0.38] 2 PLACE .XXX ± 0.01 [0.3] 3 PLACE .XXXX ± 0.005 [0.13] | DRAWN | DATE | SIZE | C |
| | APPROVED | | DWG NO. | BR1077638 |
| | CHECKED | | SCALE | 1:2 |
| | | | | SHEET 1 OF 2 |

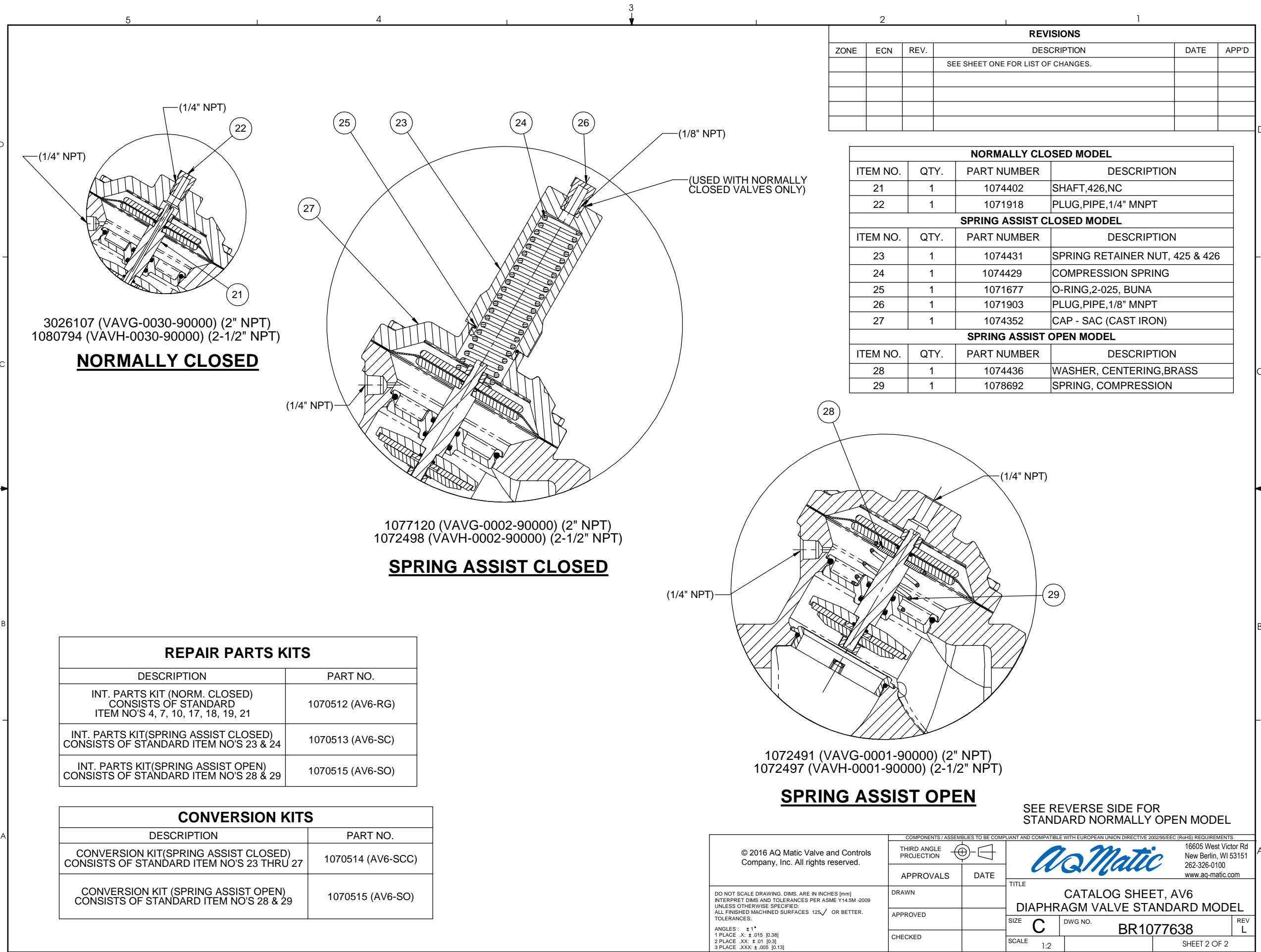

| REVISIONS | | | | | |
|-----------|-----|------|------------------------------------|------|-------|
| ZONE | ECN | REV. | DESCRIPTION | DATE | APP'D |
| | | | SEE SHEET ONE FOR LIST OF CHANGES. | | |
| | | | | | |
| | | | | | |
| | | | | | |

| NORMALLY CLOSED MODEL | | | |
|-----------------------|------|-------------|---------------------|
| ITEM NO. | QTY. | PART NUMBER | DESCRIPTION |
| 21 | 1 | 1074402 | SHAFT,426,NC |
| 22 | 1 | 1071918 | PLUG,PIPE,1/4" MNPT |

| SPRING ASSIST CLOSED MODEL | | | |
|----------------------------|------|-------------|--------------------------------|
| ITEM NO. | QTY. | PART NUMBER | DESCRIPTION |
| 23 | 1 | 1074431 | SPRING RETAINER NUT, 425 & 426 |
| 24 | 1 | 1074429 | COMPRESSION SPRING |
| 25 | 1 | 1071677 | O-RING,2-025, BUNA |
| 26 | 1 | 1071903 | PLUG,PIPE,1/8" MNPT |
| 27 | 1 | 1074352 | CAP - SAC (CAST IRON) |

| SPRING ASSIST OPEN MODEL | | | |
|--------------------------|------|-------------|-------------------------|
| ITEM NO. | QTY. | PART NUMBER | DESCRIPTION |
| 28 | 1 | 1074436 | WASHER, CENTERING,BRASS |
| 29 | 1 | 1078692 | SPRING, COMPRESSION |

3026107 (VAVG-0030-90000) (2" NPT)
1080794 (VAVH-0030-90000) (2-1/2" NPT)

NORMALLY CLOSED

1077120 (VAVG-0002-90000) (2" NPT)
1072498 (VAVH-0002-90000) (2-1/2" NPT)

SPRING ASSIST CLOSED

1072491 (VAVG-0001-90000) (2" NPT)
1072497 (VAVH-0001-90000) (2-1/2" NPT)

SPRING ASSIST OPEN

SEE REVERSE SIDE FOR STANDARD NORMALLY OPEN MODEL

| REPAIR PARTS KITS | |
|---|------------------|
| DESCRIPTION | PART NO. |
| INT. PARTS KIT (NORM. CLOSED) CONSISTS OF STANDARD ITEM NO'S 4, 7, 10, 17, 18, 19, 21 | 1070512 (AV6-RG) |
| INT. PARTS KIT (SPRING ASSIST CLOSED) CONSISTS OF STANDARD ITEM NO'S 23 & 24 | 1070513 (AV6-SC) |
| INT. PARTS KIT (SPRING ASSIST OPEN) CONSISTS OF STANDARD ITEM NO'S 28 & 29 | 1070515 (AV6-SO) |

| CONVERSION KITS | |
|--|-------------------|
| DESCRIPTION | PART NO. |
| CONVERSION KIT (SPRING ASSIST CLOSED) CONSISTS OF STANDARD ITEM NO'S 23 THRU 27 | 1070514 (AV6-SCC) |
| CONVERSION KIT (SPRING ASSIST OPEN) CONSISTS OF STANDARD ITEM NO'S 28 & 29 | 1070515 (AV6-SO) |

| | | |
|--|------------------------------|--|
| © 2016 AQ Matic Valve and Controls Company, Inc. All rights reserved. DO NOT SCALE DRAWING. DIMS. ARE IN INCHES [mm] INTERPRET DIMS AND TOLERANCES PER ASME Y14.5M-2009 UNLESS OTHERWISE SPECIFIED. ALL FINISHED MACHINED SURFACES 125/ OR BETTER. TOLERANCES: ANGLES: ± 1° 1 PLACE .X: ± 0.015 [0.38] 2 PLACE .XX: ± 0.01 [0.3] 3 PLACE .XXX: ± 0.005 [0.13] | THIRD ANGLE PROJECTION | 16605 West Victor Rd New Berlin, WI 53151 262-326-0100 www.aq-matic.com |
| | APPROVALS DATE | TITLE CATALOG SHEET, AV6 DIAPHRAGM VALVE STANDARD MODEL |
| | DRAWN APPROVED CHECKED | SIZE C DWG NO. BR1077638 SCALE 1:2 REV L |
| | SHEET 2 OF 2 | |